

8-32 UNC ∇ 3/8" [10.0mm]

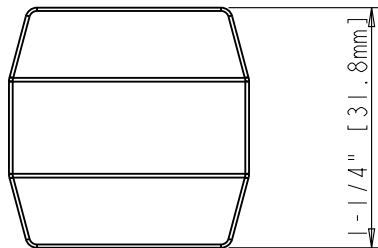
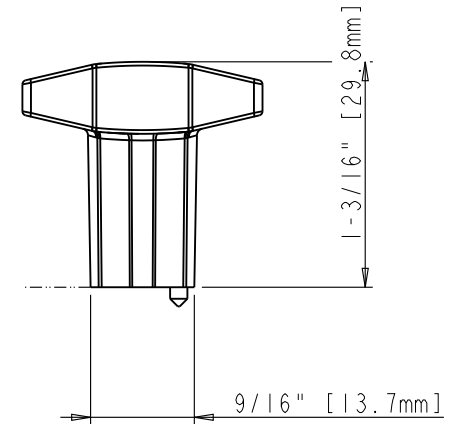
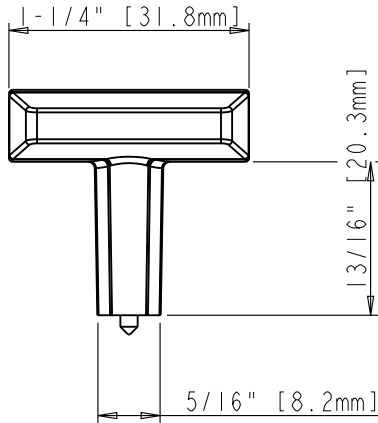
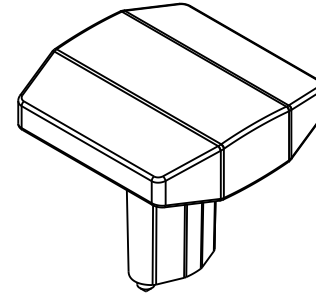

ACCESSORY:
 SCREW: 8-32x1" 1 PCS
 BREAK AWAY SCREW: 8-32x45 1 PCS
 ALL SCREW MATERIAL: STEEL-SAE1006

	ITEM#: 641		MATERIAL: Zinc		
	FINISH:		WEIGHT: 59.5 Gram/0.131 LBS		
PROPRIETARY AND CONFIDENTIAL THE INFORMATION CONTAINED IN THIS DRAWING IS THE SOLE PROPERTY OF HARDWARE RESOURCES INC. ANY REPRODUCTION IN PART OR AS A WHOLE WITHOUT THE WRITTEN PERMISSION OF HARDWARE RESOURCES INC. IS PROHIBITED.	TOLERANCE UNLESS OTHERWISE SPECIFIED: X \pm 0.20 X.X \pm 0.10 X.XX \pm 0.05 ANGULAR: \pm 0.5°		UNITS:	DRAWN BY: <i>Alan Liu</i>	DATE:
	DO NOT SCALE DRAWING		SIZE:	APPROVED BY:	DATE:
			SHEET:	RELEASE LEVEL:	REVISION: