



Product Specifications for E22456-11BZ

Job Name:	Job Type:
Quantity:	Comments:



E22456-11BZ
Saturn 3-Tier LED Pendant

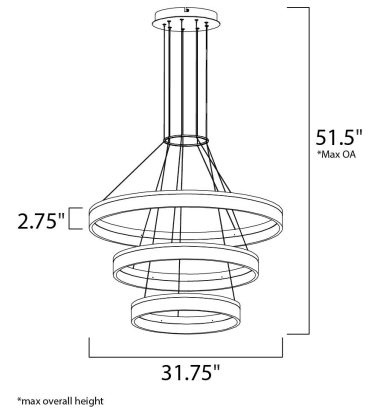

Finish
Bronze

Glass/Shade
Matte White

Product Category
Multi-Light Pendant

Lamping

Number of Bulb(s)	N/A
Light Type	LED
Bulb Type	LED
Max Bulb Wattage	70
Max Fixture Wattage	
Rated Life	N/A
Rated Lumens	±4,900
Color Temp	±3,000 K
Bulb(s) Included	Yes
Light Up/Down	N/A
Beam Spread	N/A
CRI	N/A
Photo Cell Included	N/A
Ballast/Driver/Transformer	No
Dimmable	Standard/Lutron® CL or Leviton® LED

Measurements

Width	31.75"
Height	2.75"
Length	31.75"
Extension	N/A
Back Plate Width	N/A
Back Plate Height	N/A
HCO	N/A
Min Overall Height	35.75"
Max Overall Height	51.50"
Hanging Weight	22.00 lb(s)
Height Adjustable	Yes
Slope	N/A
Chain Length	N/A
Wire Length	N/A
Canopy Width	N/A
Canopy Height	N/A
Canopy Length	N/A

Shipping

Carton Weight	29.04 lb(s)
Carton Width	33.46"
Carton Height	4.53"
Carton Length	33.46"
Carton Cubic Feet	N/A
Master Pack	1
Master Pack Weight	N/A
Master Pack Width	N/A
Master Pack Height	N/A
Master Pack Length	N/A
Master Cubic Feet	N/A
UPS Shippable	Yes

Certification

Safety Rating	Dry
Energy Star	No
CA Title 24	No
CA Title 20	No
ADA	No

Other

UPC Code	845094074502
Material	N/A

Equivalents

Incandescent Watts	N/A
Fluorescent Watts	N/A

ET2 Contemporary Lighting and all designs, logos and images © 2015 ET2 Contemporary Lighting. All Rights Reserved. ET2 Contemporary Lighting reserves the right, at any time, to make changes in the design and/or construction of the product including the discontinuation of product without prior notice. Color may vary from what is pictured above due to limitations inherent to photographic processes. Always consult a qualified, licensed electrician before installation of any product weighing 35 pounds or more. We recommend that a qualified, licensed electrician do the installation. Always install to a mechanically sound structure.